

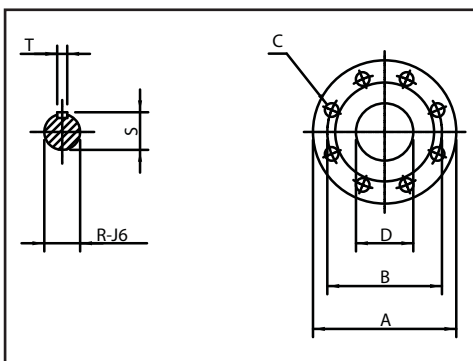

Målskitser/Dimensional Sketches/Massblätter

ROTAN® GP/HD/PD/CD/ED

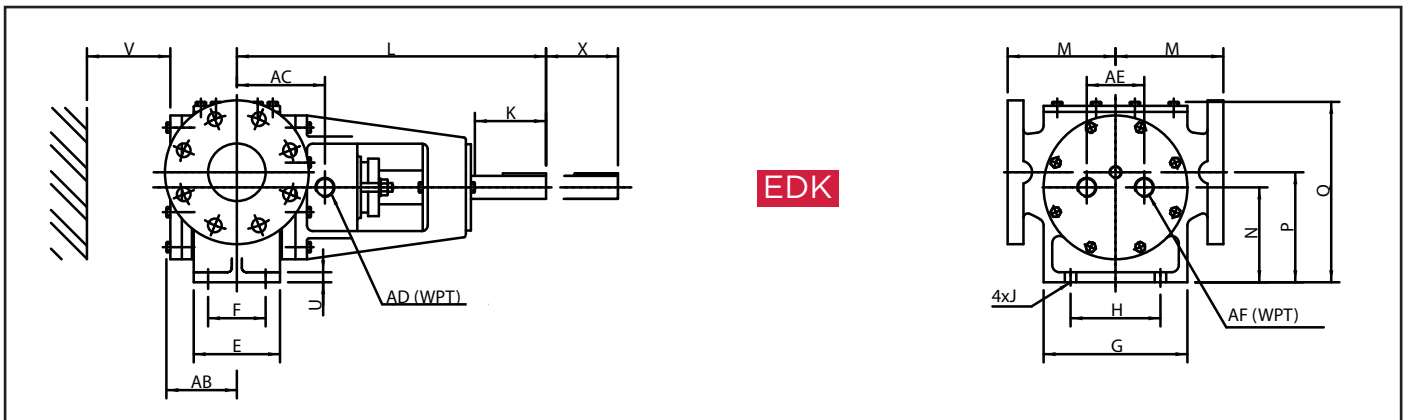
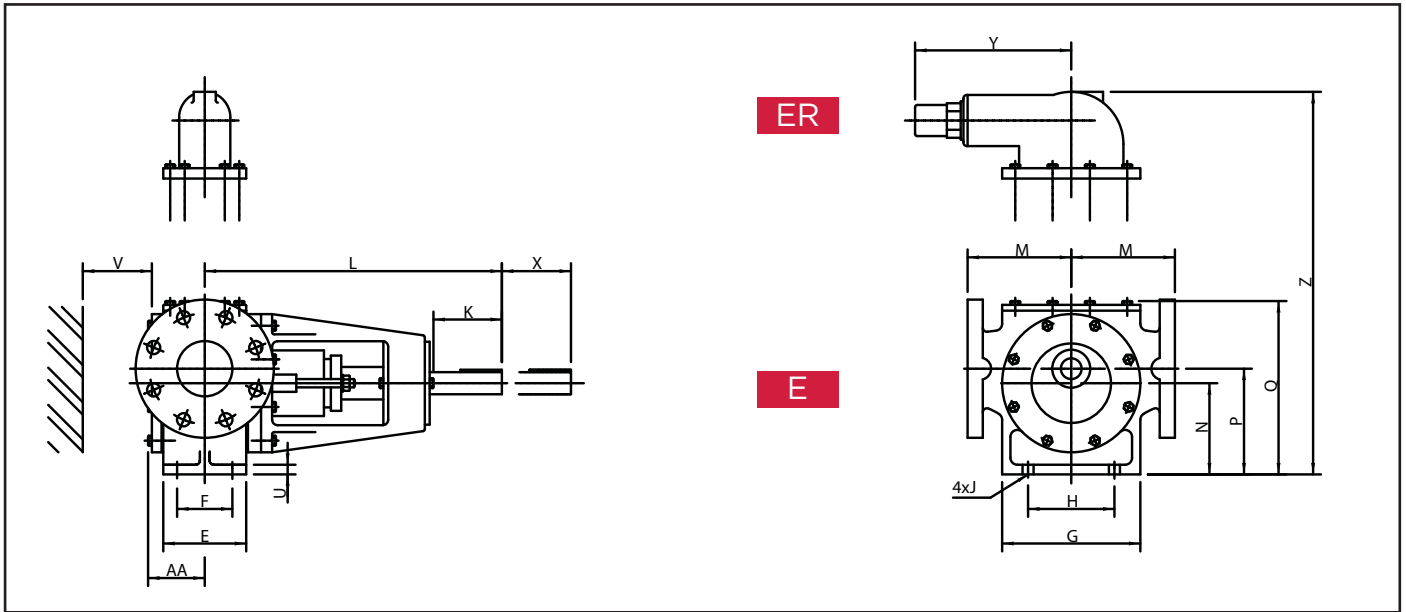

Type Typ	Manometertilslutning Pressure gauge connection Manometeranschlüsse
26-66	1/4" RG 1/4" WPT 1/4 Rohrgewinde
81-201	3/8" RG 3/8" WPT 3/8" Rohrgewinde

Flanger / Flanges / Flanschen	
ISO 2084/ DIN 2501 / BS 4504 : 1969	
Type Typ	Tryktrin Nominal pressure Nennndruck
26-81	PN 16
101-201	PN 10

Type Typ	Alle udførelser / All configurations / Alle Ausführungen																			ER		E		EDK				Weight KG			
	A	B*	C*	D	E	F	G	H	J	K	L	M	N	P	Q	R	S	T	U	V	X	Y	Z	AA	AB	AC	AD	AE	AF	Pump	Valve
HD26	115	85	4-Ø14	25	45	28	90	50	Ø7	40	220	60 83	71	79	126	Ø12	13,5	4	8	50	70	115	176 202	34	52	42	3/8"	38	3/8"	5,5	2
HD33	140	100	1 1/4" WPT female or 4-Ø18	32	45	28	90	50	Ø7	40	224	60 83	71	79	126	Ø12	13,5	4	8	60	80	115	172 202	38	56	45	3/8"	38	3/8"	6	2
HD41	150	110	1 1/2" WPT female or 4-Ø18	40	70	50	120	65	Ø10	48	253	90 100	100	110	175	Ø16	18	5	10	65	55	115	238	48	58	61	3/8"	50	3/8"	14	2
HD51	165	125	4-Ø19	50	85	60	160	95	Ø12	66	345	125	112	126	213	Ø27	30	8	12	70	70	199	288	61	74	103	1/2"	70	1/2"	35	6
HD66	190	145	4-Ø19	65	95	60	160	95	Ø12	66	350	125	112	126	213	Ø27	30	8	12	80	80	199	288	66	79	114,5	1/2"	70	1/2"	40	6
HD81	210	160	8-Ø19	80	120	80	200	125	Ø15	103	430	150	132	153	257	Ø32	35,5	10	14	100	100	226	363	82	98	127,5	3/4"	80	3/4"	65	10
HD101	229	180	8-Ø19	100	140	110	245	160	Ø15	103	435	180	160	187	307	Ø32	35,5	10	14	115	115	226	413	92	108	127,5	3/4"	90	3/4"	90	10
HD124	229	180	8-Ø19	100	160	120	280	190	Ø19	121	565	205	200	231	367	Ø42	45,5	12	18	140	140	326	525	107	123	150	1"	112	3/4"	138	20
HD126	254	210	8-Ø19	125	160	120	280	190	Ø19	121	565	200	200	231	367	Ø42	45,5	12	18	140	140	326	525	107	123	150	1"	112	3/4"	140	20
HD151	285	240	8-Ø24	150	190	150	330	250	Ø19	121	580	225	225	262	418	Ø42	45,5	12	18	165	165	326	575	125	145	165	1"	130	3/4"	190	20
HD152	285	240	8-Ø24	150	220	160	390	280	Ø24	133	644	275	250	295	480	Ø55	60	16	22	180	180	443	690	144	166	197	1"	140	3/4"	280	60
HD201	340	295	8-Ø24	200	250	200	465	315	Ø24	180	850	300	315	369	582	Ø70	76	20	24	215	215	443	792	168	193	240	1"	200	3/4"	460	60

* Andre dimensioner ved ANSI / Other dimensions by ANSI / Andre Dimensionen bei ANSI

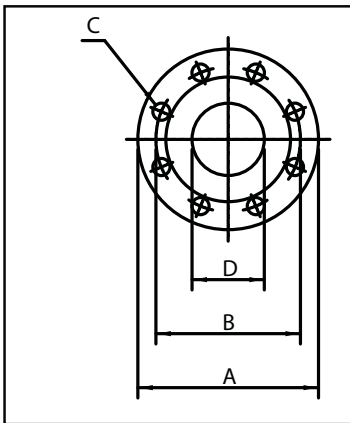
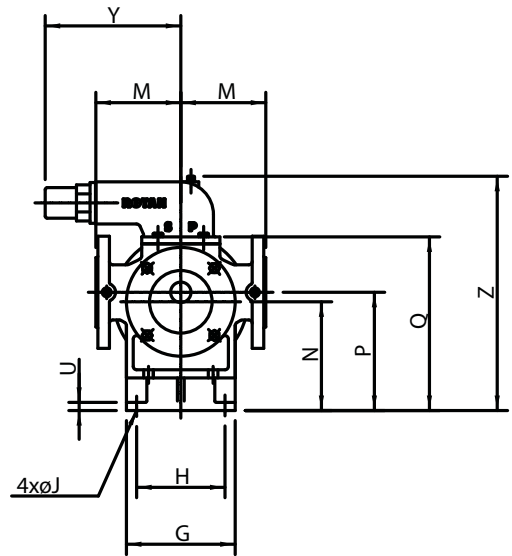
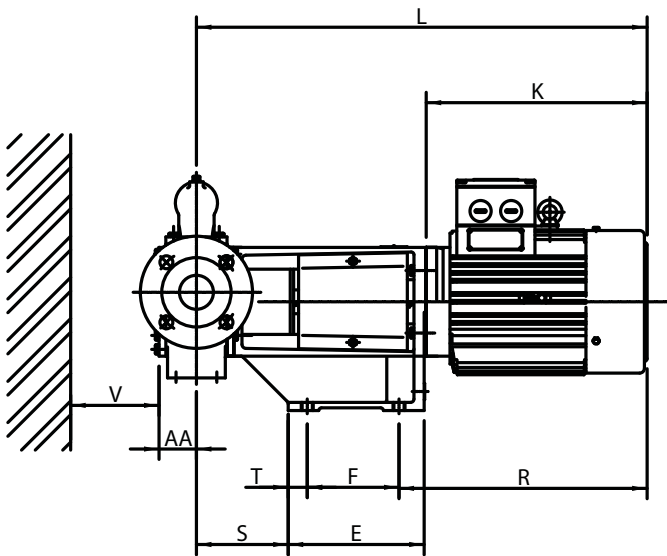

Type Typ	Manometer tilslutning Pressure gauge connectoin Manometeranschlüsse
26-66	1/4" RG 1/4" WPT 1/4" Rohrgewinde
81-101	3/8" RG 3/8" WPT 3/8" Rhorgewinde

IEC- / DIN Motorer	
Byggestørrelse / Motor size	Byggeform / Mounting arrangement
80-112	B14
132-160	B5

Flanger / Flanges / Flanschen	
ISO 2084 / DIN 2501 / BS 4504 : 1969	
Type Typ	Tryktrin Nominal pressure Nenndruck
26-81	PN 16
101	PN 10

Type	Motor	A	B	C	D	E	F	G	H	J	K	L	M	N	P	Q	R	S	T	U	V	Y	Z	AA	Weight KG		
																									Pump	Valve	
GP 26	80	115	85	1" WPT female or 4-Ø14	21	125	65	120	90	12	255	464	60	112	120	167	297	82	20	10	50	115	243	34	11	2	
	90S					130	70	140	110		265	484	83				307	87									
	90L					290	509		332																		
GP 33	80	140	100	1 1/4" WPT female or 4-Ø18	32	125	65	120	90	12	255	468	60	132	140	187	297	86	91	20	10	60	115	243	38	12	2
	90S					130	70	140	110		290	513	83				307										
	90L					325	559		332																		
GP 41	100L	150	110	1 1/2" WPT female or 4-Ø18	40	140	80	140	110	15	325	559	90	132	142	207	340	604	101	20	10	65	156	270	48	20	2
	90S					150	90	140	110		290	544	100				307										
	90L					325	589		332																		
GP 51	100L	165	125	4-Ø19	50	200	135	160	130	15	325	663	125	160	174	261	325	663	135	25	70	199	336	61	50	6	
	112M4										340	678					383										
	112M2,6,8										340	678					383										
	132S										390	748					450										
	132SX										399	757					459										
	132MX,8										430	788					490										
	132M4, MX6										430	788					490										
	100L										325	668					368										
	112M4										325	668					368										
	112M2,6,8										340	683					383										
GP 66	100L	190	145	4-Ø19	65	200	135	160	130	15	325	668	125	160	174	261	325	668	140	25	80	199	336	66	55	6	
	112M4										340	683					383										
	112M2,6,8										340	683					383										
	132S										390	753					450										
	132SX										399	762					459										
	132MX,8										430	793					490										
	132M4, MX6										430	793					490										
	160MX,8										505	898					565										
	160M4,6,8										505	898					565										
	100L										390	792					450										
GP 81	132SX,8	210	160	8-Ø19	80	220	140	225	195	15	430	832	150	200	221	325	430	832	177	25	16	100	226	431	82	80	10
	132MX,8										430	832					490										
	160MX,8										505	937					565										
	160M6,8										505	937					565										
	160L6,8										560	992					620										
	132MX,8										430	837					490										
GP 101	132MX,8	229	180	8-Ø19	100	220	140	225	195	15	430	837	180	200	227	347	430	837	182	25	16	115	226	453	92	105	10
	160MX,8										505	942					565										
	160M6,8										505	942					565										
	160L6,8										560	997					620										
	180L6,8										590	1027					650										
	132MX,8										430	837					490										

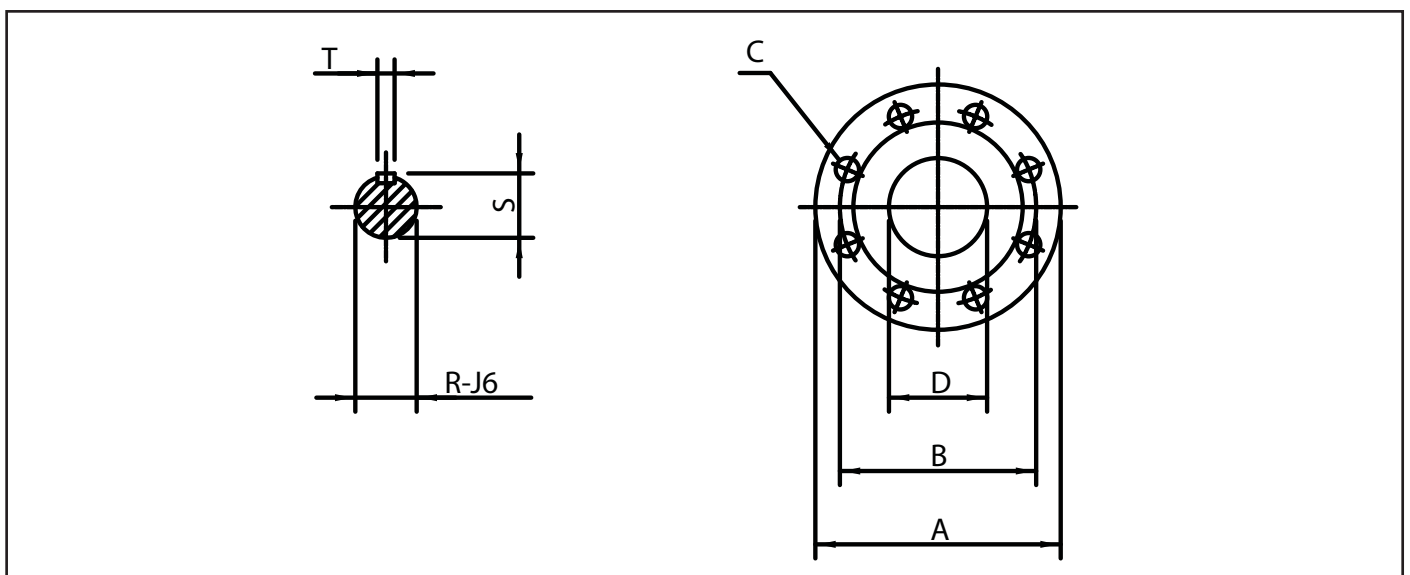
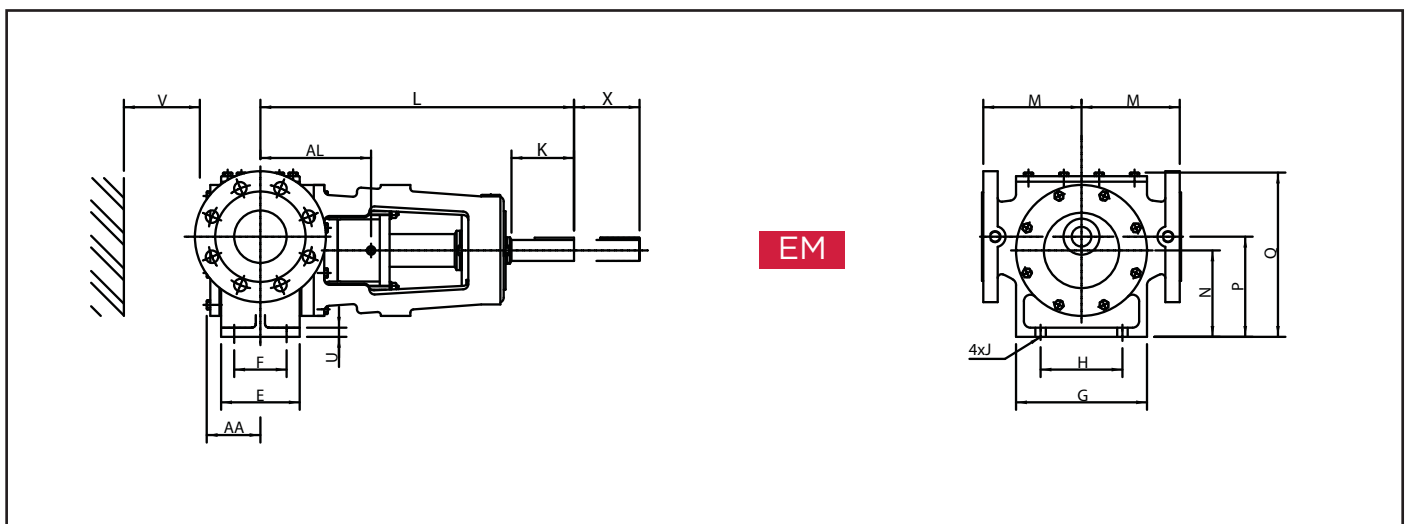
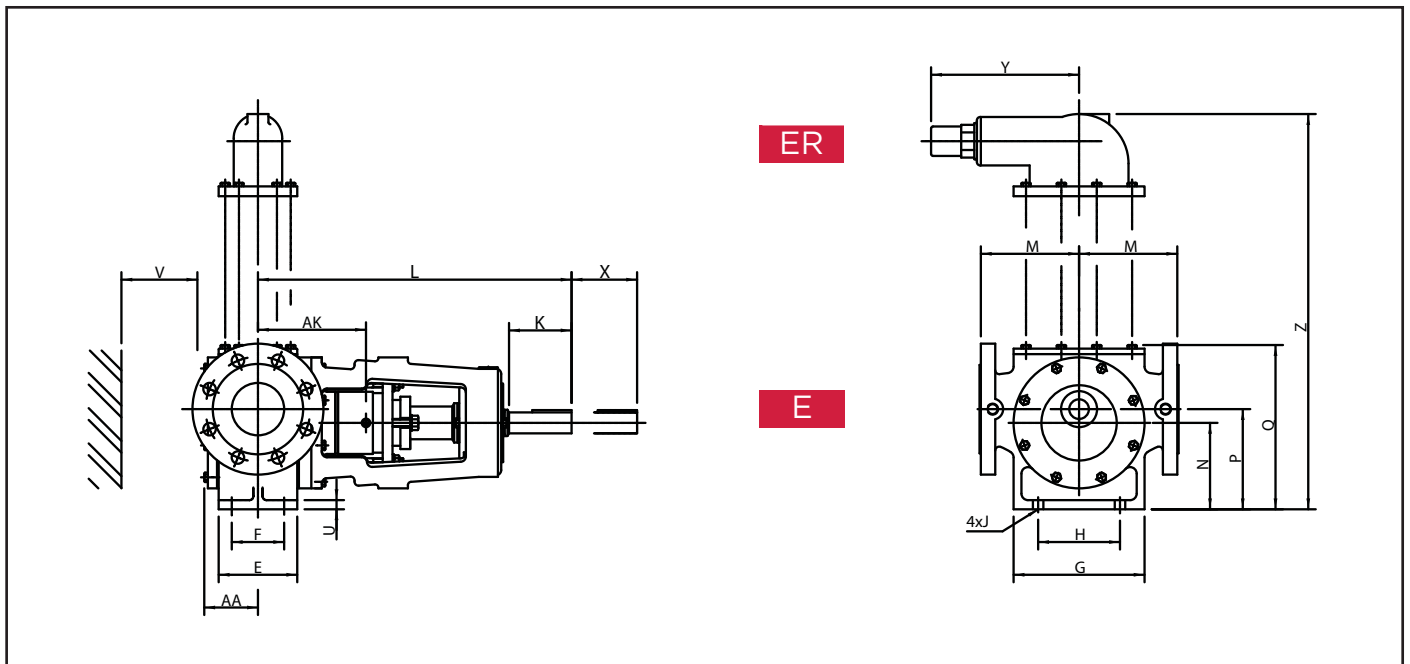

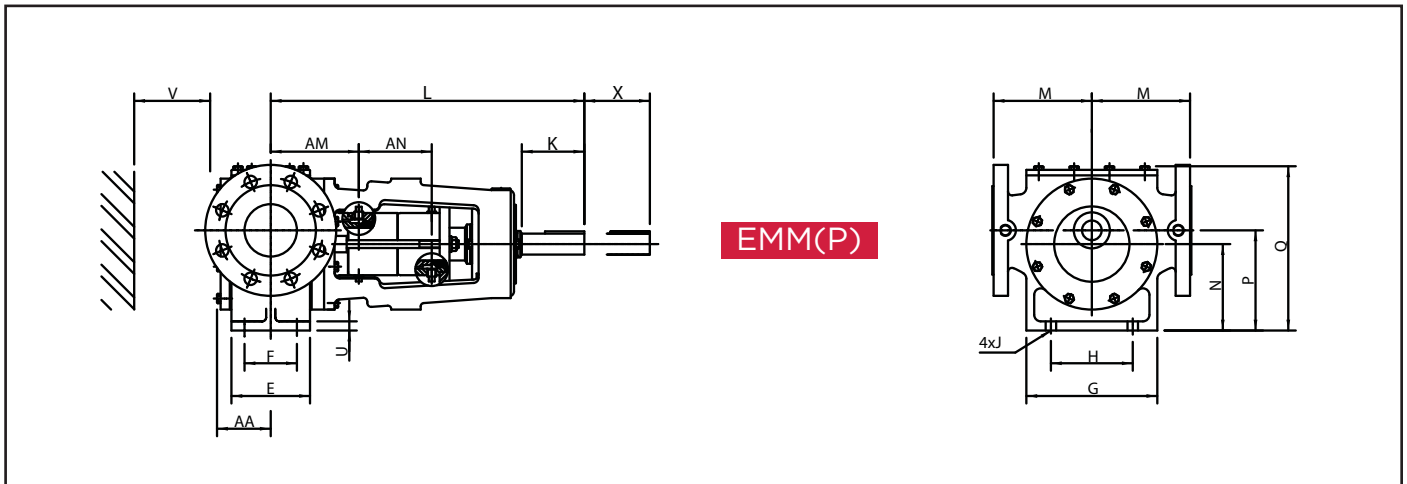

EMM(P)

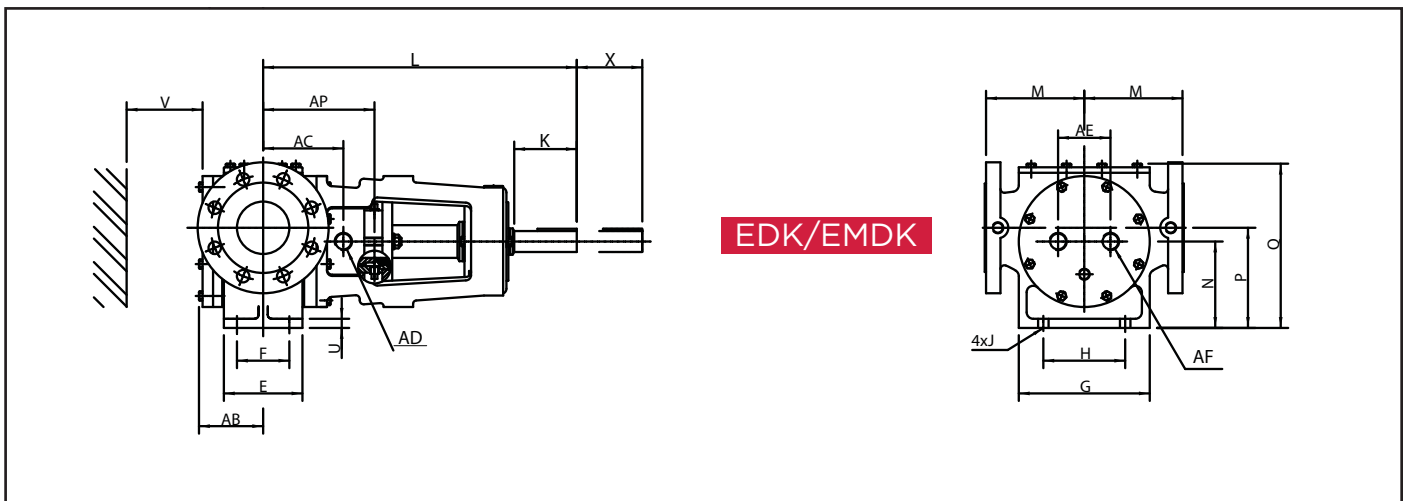

EDK/EMDK

Type Typ	Manometertilslutning Pressure gauge connection Manometeranschlüsse
26-66	1/4" RG 1/4" WPT 1/4" Rohrgewinde
81-201	3/8" RG 3/8" WPT 3/8" Rohrgewinde

Type Typ	Tilslutning for spærrevæske
26-41	1/8" RG 1/8" WPT 1/8" Rohrgewinde
51-151	1/4" RG 1/4" WPT 1/4" Rohrgewinde
201	3/8" RG 3/8" WPT 3/8" Rohrgewinde

Flanger / Flanges / Flanschen				
Type Typ	ISO	DIN	BS	ANSI
26-101	2084-PN16	2501-ND16	4504 1969 PN16	B 16,5 Class 150
126-201	2084-PN10	2501-ND10	4504 1969 PN10	B 16,5 Class 150

Type Typ	Alle udførelser / All configurations / Alle Ausführungen																			E		ER		EM		EMM		EDK/EMDK						Weight KG		
	A	B*	C*	D	E	F	G	H	J	K	L	M	N	P	Q	R	S	T	U	V	X	AA	AK	Y	Z	AL	AM	AN	AB	AC	AD	AE	AF	AP	Pump	Valve
PD26	115	85	4-Ø14	25	45	28	90	50	Ø7	40	249	83	71	79	126	Ø12	13,5	4	8	50	70	34	76	115	202	77	57	62	52	33	1/8"	38	3/8"	76	7	2
PD33	140	100	4-Ø18	32	45	28	90	50	Ø7	40	253	83	71	79	126	Ø12	13,5	4	8	60	80	38	80	115	202	81	61	62	56	36	1/8"	38	3/8"	80	10	2
PD41	150	110	4-Ø18	40	70	50	120	65	Ø10	48	293	100	100	110	175	Ø16	18	5	10	65	55	48	89	115	248	94	97	55	58	46	1/4"	50	3/8"	95	18	2
PD51	165	125	4-Ø19	50	85	60	160	95	Ø12	66	357	125	112	126	213	Ø27	30	8	12	70	70	61	116	199	288	124	94	92	74	55	1/4"	70	1/2"	124	36	6
PD66	190	145	4-Ø19	65	95	60	160	95	Ø12	66	362	125	112	126	213	Ø27	30	8	12	80	80	66	118	199	288	127	95	91	79	60	1/4"	70	1/2"	119	43	6
PD81	210	160	8-Ø19	80	120	80	200	125	Ø15	103	488	150	132	153	257	Ø32	35,5	10	14	100	100	82	165	226	363	169	134	111	98	120	1/2"	80	3/4"	170	70	10
PD101	229	180	8-Ø19	100	140	110	245	160	Ø15	103	493	180	160	187	307	Ø32	35,5	10	14	115	115	92	175	226	413	175	144	116	108	126	1/2"	90	3/4"	170	96	10
PD126	254	210	8-Ø19	125	160	120	280	190	Ø19	121	585	200	200	231	367	Ø42	45,5	12	18	140	140	107	214	326	525	229	195	127	123	165	1/2"	112	3/4"	215	152	20
PD151	285	240	8-Ø24	150	190	150	330	250	Ø19	121	600	225	225	262	418	Ø42	45,5	12	18	165	165	125	229	326	575	244	210	127	145	180	1/2"	130	3/4"	230	205	20
PD201	340	295	8-Ø24	200	250	200	465	315	Ø24	180	850	300	315	369	582	Ø70	76	20	24	215	215	168	305	443	792	327	270	133	193	221	1"	200	3/4"	327	500	60

* Andre dimensioner ved ANSI / Other dimensions by ANSI / Andere Dimensionen bei ANSI

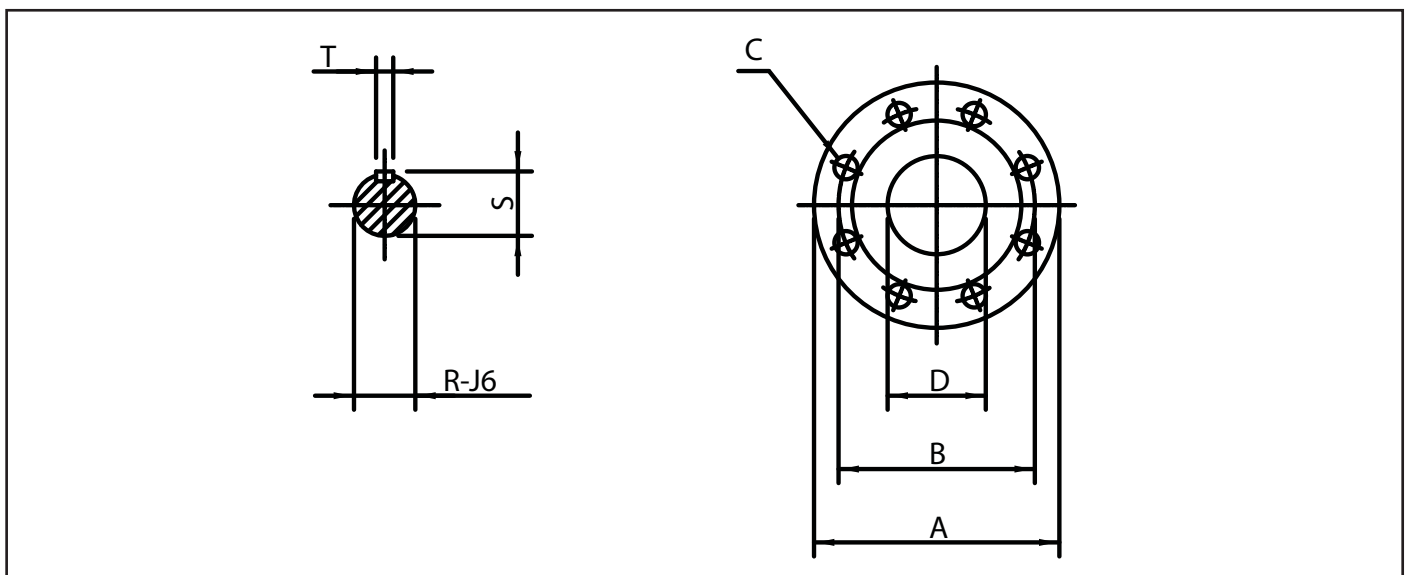
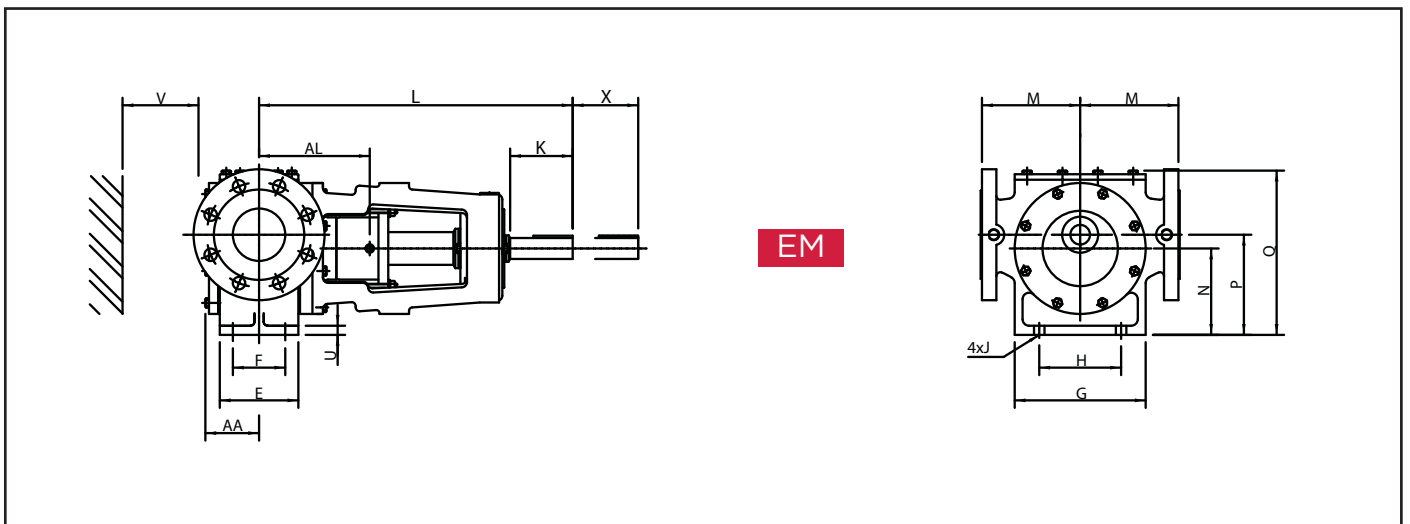
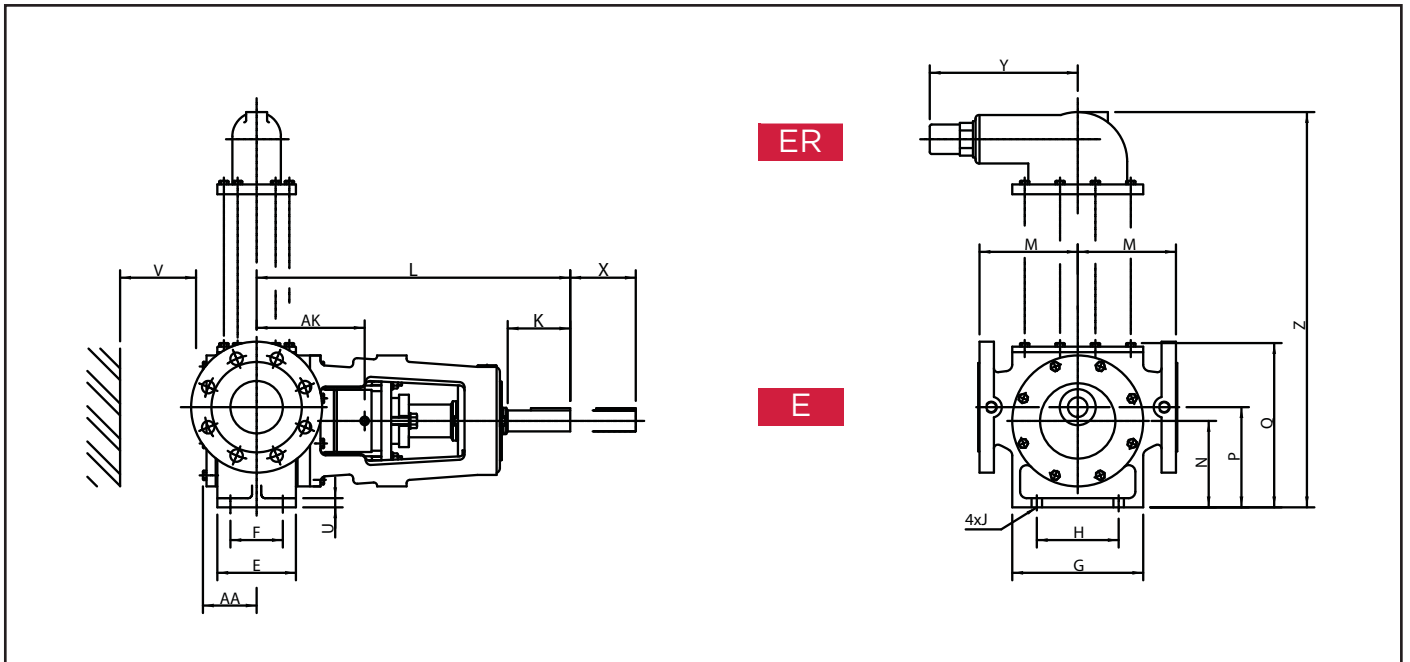

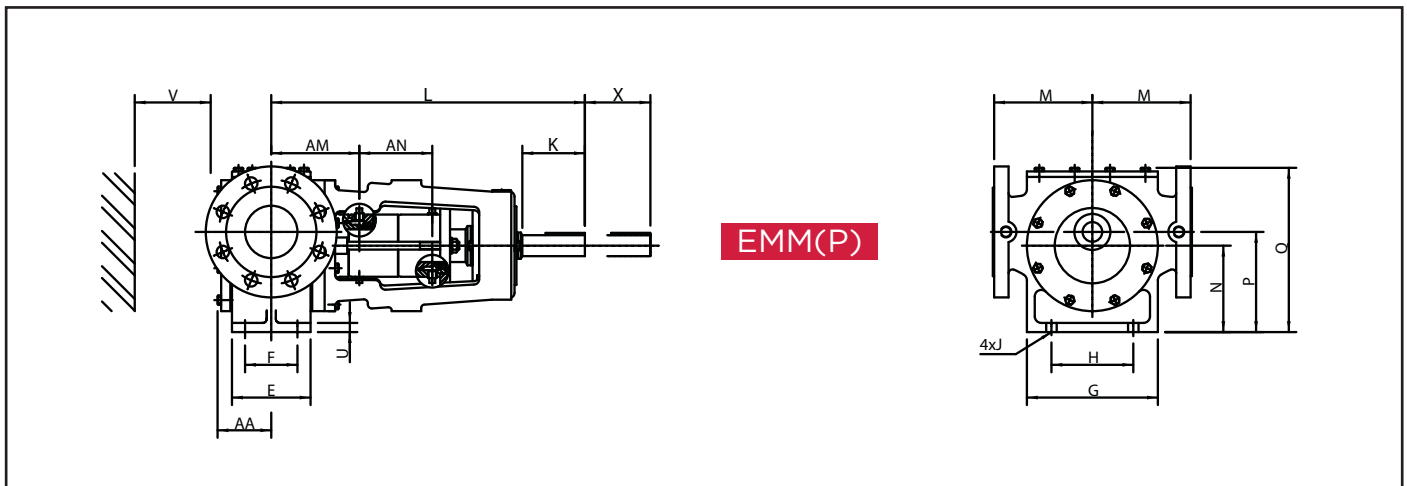

EMM(P)

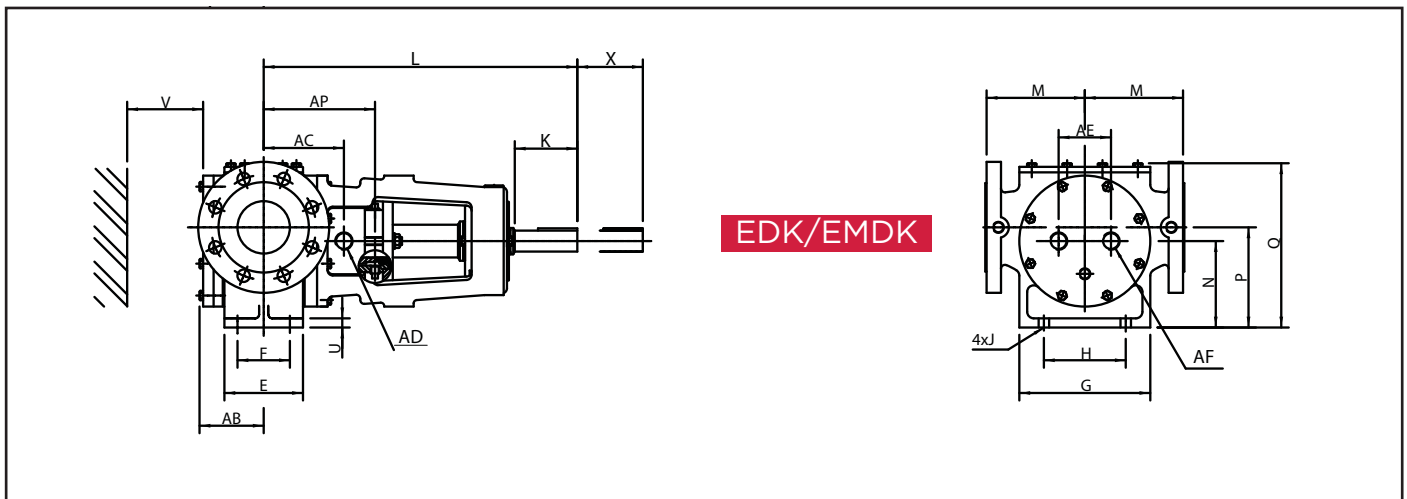

EDK/EMDK

Type Typ	Manometertilslutning Pressure gauge connection Manometeranschlüsse
26-66	1/4" RG 1/4" WPT 1/4" Rohrgewinde
81-201	3/8" RG 3/8" WPT 3/8" Rohrgewinde

Type Typ	Tilslutning for spærrevæske Sealing liquid connection Anschluß für Sperrflüssigkeit
26-41	1/8" RG 1/8" WPT 1/8" Rohrgewinde
51-151	1/4" RG 1/8" WPT 1/8" Rohrgewinde
201	3/8" RG 3/8" WPT 3/8" Rohrgewinde

Flanger / Flanges / Flanschen				
Type Typ	ISO	DIN	BS	ANSI
26-101	2084-PN16	2501-ND16	4504-1969 PN16	B 16,5 Class 150
126-201	2084-PN10	2501-ND10	4504-1969 PN10	B 16,5 Class 150

Type Typ	Alle udførelser / All configurations / Alle Ausführungen																				E		ER		EM		EMM		EDK/EMDK					Weight KG		
	A	B*	C*	D	E	F	G	H	J	K	L	M	N	P	Q	R	S	T	U	V	X	AA	AK	Y	Z	AL	AM	AN	AB	AC	AD	AE	AF	AP	Pump	Valve
CD26	115	85	4-Ø18	25	45	28	90	50	Ø7	40	249	60	71	79	126	Ø12	13,5	4	8	50	70	34	76	115	202	79	57	62	52	33	1/8"	38	3/8"	76	7	2
CD33	140	100	4-Ø18	32	45	28	90	50	Ø7	40	253	60	71	79	126	Ø12	13,5	4	8	60	80	38	80	115	202	81	61	62	56	36	1/8"	38	3/8"	80	10	2
CD41	150	110	4-Ø18	40	70	50	120	65	Ø10	48	293	100	100	110	175	Ø16	18	5	10	65	55	48	89	115	248	94	97	55	58	46	1/4"	50	3/8"	95	18	2
CD51	165	125	4-Ø19	50	85	60	160	95	Ø12	66	357	125	112	126	213	Ø27	30	8	12	70	70	61	116	199	288	124	94	92	74	55	1/4"	70	1/2"	124	36	6
CD66	190	145	4-Ø19	65	95	60	160	95	Ø12	66	362	125	112	126	213	Ø27	30	8	12	80	80	66	118	199	288	127	95	91	79	60	1/4"	70	1/2"	119	43	6
CD81	210	160	8-Ø19	80	120	80	200	125	Ø15	103	488	150	132	153	257	Ø32	35,5	10	14	100	100	82	165	226	363	169	134	111	98	120	1/2"	80	3/4"	170	70	10
CD101	229	180	8-Ø19	100	140	110	245	160	Ø15	103	493	180	160	187	307	Ø32	35,5	10	14	115	115	92	175	226	413	175	144	116	108	126	1/2"	90	3/4"	170	96	10
CD126	254	210	8-Ø19	125	160	120	280	190	Ø19	121	585	200	200	231	367	Ø42	45,5	12	18	140	140	107	214	326	525	229	195	127	123	165	1/2"	112	3/4"	215	152	20
CD151	285	240	8-Ø24	150	190	150	330	250	Ø19	121	600	225	225	262	418	Ø42	45,5	12	18	165	165	125	229	326	575	244	210	127	145	180	1/2"	130	3/4"	230	205	20
CD152	285	240	8-Ø24	150	220	160	390	280	Ø24	133	644	275	250	295	480	Ø55	60	16	22	180	180	144	255	443	690	267	247**	90**	166	200	1"	140	3/4"	283	335	60
CD201	340	295	8-Ø24	200	250	200	465	315	Ø24	180	850	300	315	369	582	Ø70	76	20	24	215	215	168	305	443	792	327	270	133	193	221	1"	200	3/4"	327	500	60

* Andre dimensioner ved ANSI / Other dimensions by ANSI / Andere Dimensionen bei ANSI

** Mål for EMMPW / Measures for EMMPW / Dimensionen für EMMPW

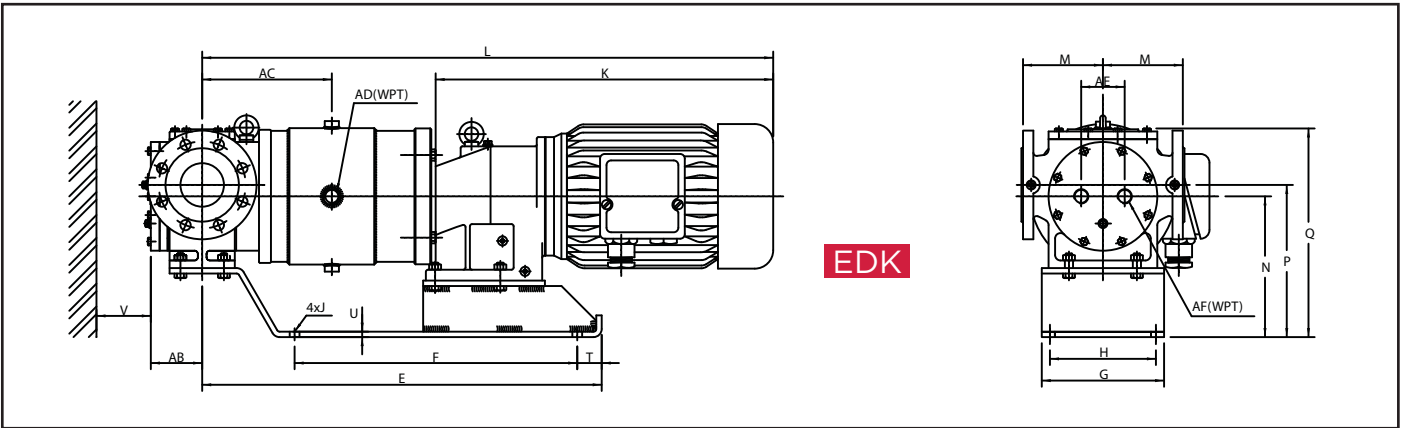
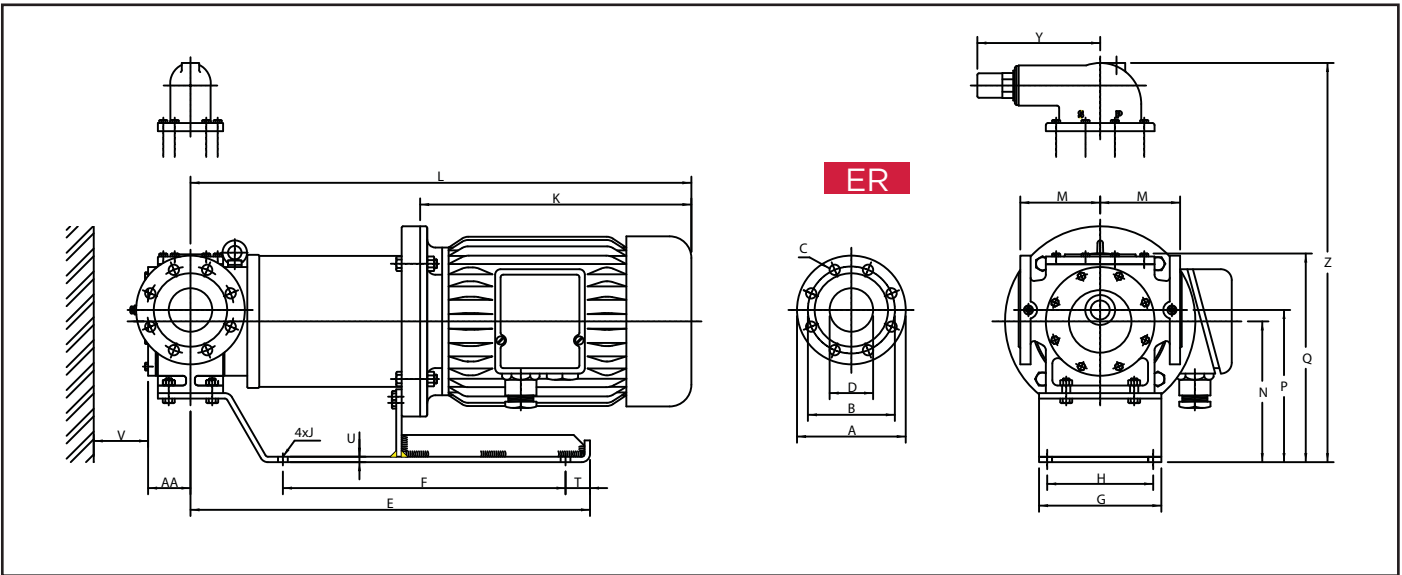

IEC- / DIN Motors	
IEC 100/112 ED26/33/41	Large B14
All other motors	B5

Type Typ	Manometertilslutning Pressure gauge connection Manometeranschlüsse
26-66	1/4" RG 1/4" WPT 1/4" Rohrgewinde
81-201	3/8" RG 3/8" WPT 3/8" Rohrgewinde

Flanger / Flanges / Flanschen				
Type Typ	ISO	DIN	BS	ANSI
26-101	2084-PN16	2501-ND16	4504-1969 PN16	B 16,5 Class 150
126-201	2084-PN10	2501-ND10	4504-1969 PN10	B 16,5 Class 150

Type	Motor Gear	Alle udførelser / All configurations / Alle Ausführungen																	Weight KG													
		A	B**	C	D	E	F	G	H	J	K*	L*	M	N	P	Q	T	U	V	Y	Z	AA	AB	AC	AD	AE	AF	pump	valve			
ED 26	IEC 80/90	115	85	4-Ø14	25	434					209..303	459..553	60							50	115	254	35	43	162					29		
	IEC 100/112										272..340	522..590										83									284	
	Gearmotor										358..512	619..775										83									284	
ED 33	IEC 80/90	140	100	4-Ø18	32	438	300	140	110	Ø14	209..303	463..557	60	152	160	209				36	8	60							38			
	IEC 100/112										272..340	526..594																		83	284	
	Gearmotor										358..512	623..779																		83	284	
ED 41	IEC 90	150	110	4-Ø18	40	446					303	565	90	170	180	244				65	156	309	45	56	174		50		40			
	IEC 100/112										272..340	534..602																		100	284	
	Gearmotor										403..552	680..829																		100	284	
ED 51	IEC 100/112	165	125	4-Ø19	50	595	400	160	130		272..340	513..681	125	236	250	335				70		199	413	56	70	186		70	1/2"	6		
	IEC 132										430	771																			125	284
	IEC 160										468..722	812..1071																			125	284
ED 66	IEC 100/112	190	145	4-Ø19	65	600				Ø18	272..340	518..686	150	259	280	384				45	10	80		61	75	191		95				
	IEC 132										430	776																		45	284	
	IEC 160										468..722	817..1076																		45	284	
ED 81	IEC 132	210	160	8-Ø19	80	735					430	853	150	259	280	384				100	226	490	78	95	239		80		10			
	IEC 160/180										560..630	872..1033																		100	284	
	Gearmotor										567..855	997..1303																		100	284	
ED 101	IEC 132	229	180	8-Ø19	100	740	520	225	195		430	858	180	273	300	420				115		526	88	105	244		90	3/4"	10			
	IEC 160										560..630	988..1068																		115	284	
	Gearmotor										567..855	997..1303																		115	284	
ED 126	IEC 200	254	210	8-Ø19	125	851					560	1164	200	284	315	451				70	12	140	326	607	101	118	339		112	20		
	IEC 200										585..855	1144..1416																			12	284
	Gearmotor										660	1179																			12	284
ED 151	IEC 200	285	240	8-Ø24	150	866					640..855	1216..1431	225	278..318	315..355	470..510				165		628..668	119	140	358		130		20			
	Gearmotor										640..855	1216..1431																		165	284	

* Præcise dimensioner på forespørgsel / Precise measures on request. / Genaue Dimensionen an anfrage ** Andre dimensioner ved ANSI / Other dimensions by ANSI / Andre Dimensionen Bei ANS