



Model FT10A 메탈

AIR OPERATED DOUBLE DIAPHRAGM PUMPS



펌프 사양

- 흡입 / 토출 사이즈 : 1" x 1"
- 표준 포팅 위치 : 끝
- 파이프 연결 타입 : FNPT, FBSPT
- 에어 흡입/배기 사이즈 : 1/2" FNPT x 1/2" FNPT
- * NPT 혹은 BSP 드레드 센타포토 위치 수평 혹은 수직 옵션.

펌프 능력 / 용량

- 최대유량 : 212 lpm
- 최대 에어공급 압 : 8.3 Bar
- 한타당 용적량 : 0.19 Liter
- 최소 에어흡입 압 : 0.7 Bar
- 입자 최대 사이즈 : 6.4 mm
- 소음 기준 : 73.6 dB(A)
- 가동온도 : 탄성체에 의해 결정.

FT10 Performance

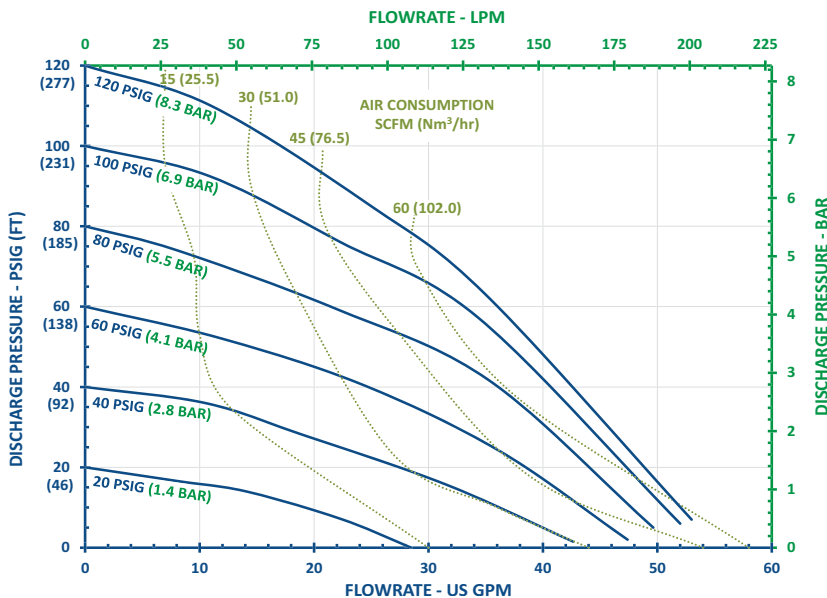

Note: Full stroke diaphragm allows performance to be equal for all elastomers.

Typical Applications

- Acids & Bases
- Plating Solutions
- Wastewater
- Paints, Inks, Solvents
- Ceramic Slip and Glaze
- Lubricants and Oils

Typical Industries

- Mining
- Paints and Coatings
- Ceramics
- Pulp and Paper
- Electroplating & Anodizing
- Wastewater
- Marine
- Chemical Manufacturing & Distribution
- OEM's

CHANGE IS IN THE AIR

펌프 구조

- 접습면 : 알루미늄
- 다이어프램 재질 : 네오프렌, 산티프렌, FKM, EPDM, PTFE, Buna, Hytrel, Polyurethane
- 에어 밸브 : GFRP, 알루미늄
- 볼 재질 : 네오프렌, Buna, EPDM, FKM, 산티프렌, PTFE
- 시트 재질 : 알루미늄, 스텐 SS316, PTFE,
- 오링 재질 : 네오프렌, Buna, EPDM, FKM, PTFE, FEP/FKM

* 산티프렌은 엑슨모빌사의, 하이트렐은 듀폰사의 등록 상표임.

펌프 사이즈

- 최대높이 : 366 mm
- 최대넓이 : 375 mm
- 최대깊이 : 271 mm

펌프 무게

- 알루미늄 : 15.5 Kg

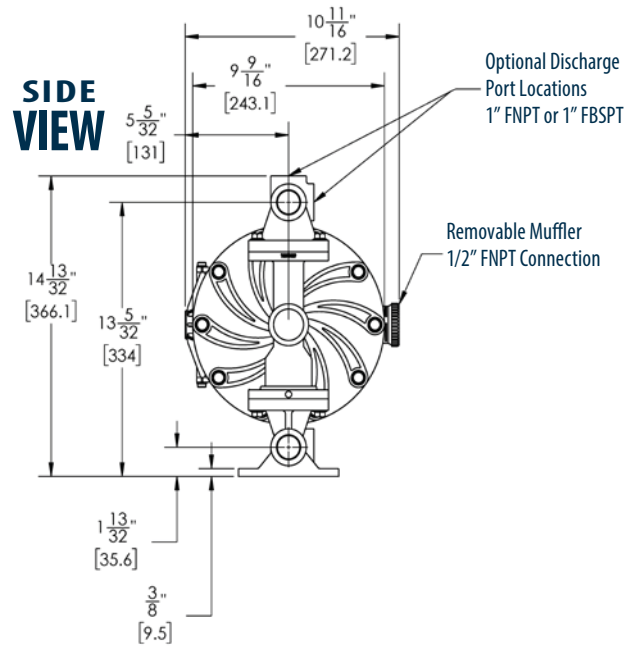
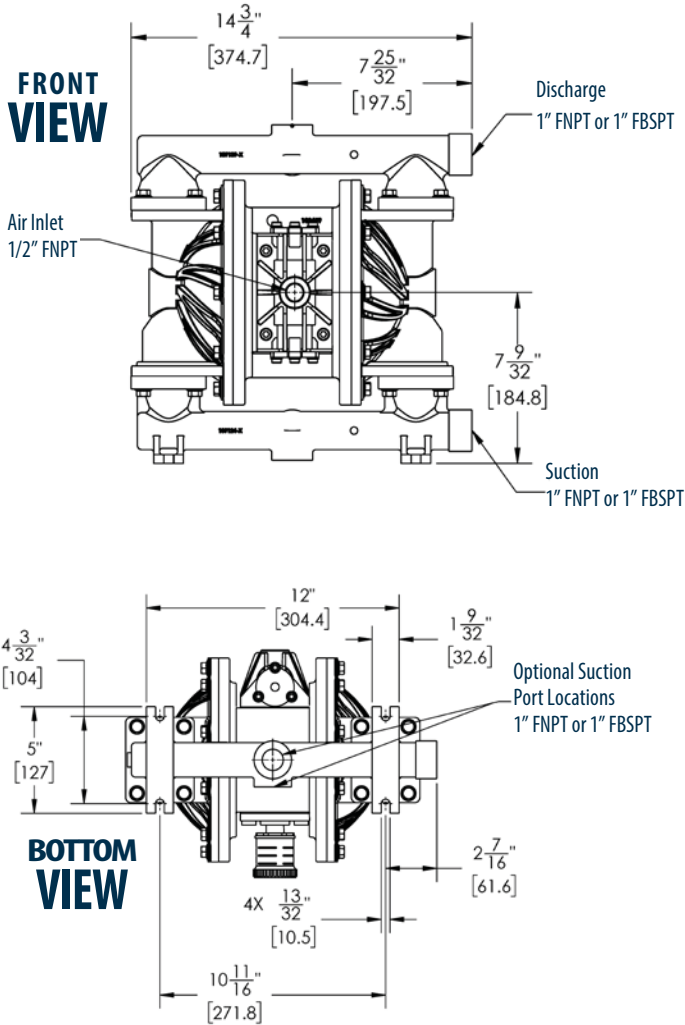

FTI AIR

921 GREENGARDEN ROAD ERIE, PA 16501
Tel: (800) 934-9384 • Fax: (814) 459-3460
www.FTIAIR.com

