



# Model FT15 프락스틱

## AIR OPERATED DOUBLE DIAPHRAGM PUMPS

### 펌프 사양

- 흡입/토출 구경 : 1.5" x 1.5"
- 포트 위치 : 끝
- 배관연결 타입 : ANSI/DIN/ISO Flange
- 공기 흡입&배기 사이즈 : 3/4" FNPT x 3/4" FNPT

### 펌프 능력/용량

- 최대유량 : 473 lpm
- 최대 공기공급압 : 6.9 Bar
- 한타당 용적 : 1.2 Liter
- 최소 공기흡입 압 : 0.7 Bar
- 입자 최대사이즈 : 89mm
- 소음레벨 : 77 dB(A)
- 가동온도 : 탄성체에 의해 결정



### FT15 Performance

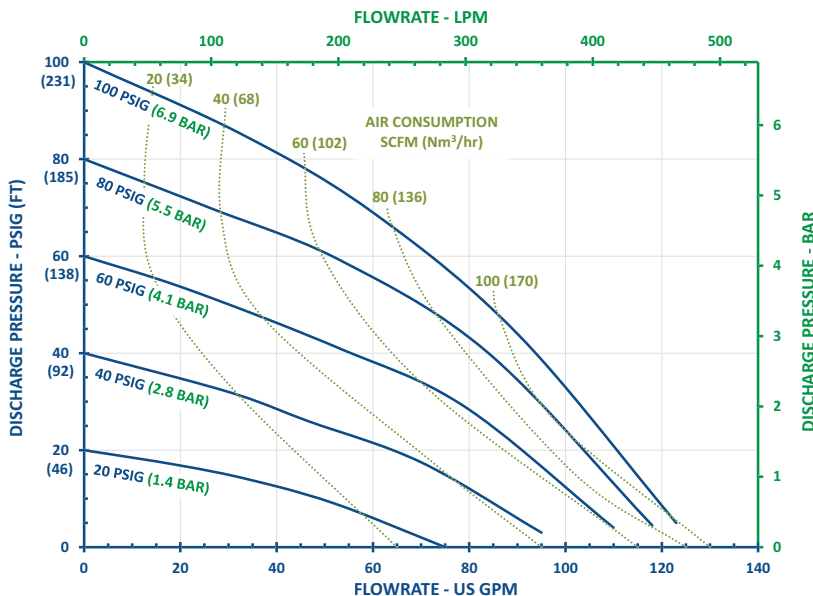

Note: Full stroke diaphragm allows performance to be equal for all elastomers.

### Typical Applications

- Acids & Bases
- Plating Solutions
- Wastewater
- Paints, Inks, Solvents
- Ceramic Slip and Glaze
- Lubricants and Oils

### Typical Industries

- Mining
- Paints and Coatings
- Ceramics
- Pulp and Paper
- Electroplating & Anodizing
- Wastewater
- Marine
- Chemical Manufacturing & Distribution
- OEM's

## 펌프의 구조

- 접습면 재질 : 폴리프로피렌, PVDF
- 다이어프램 재질 : 네오프렌, 산토프렌, FKM, EPDM, PTFE, Buna, Hytrel Polyurethane
- 에어밸브 : GFRP, 알루미늄
- 볼 재질 : 네오프렌, Buna, EPDM, FKM, 산토프렌, PTFE
- 시트 재질 : 폴리프로피렌, PVDF
- 오링 재질 : Buna, FKM, 산토프렌, 폴리우레탄, FEP/FKM

\* 산토프렌은 엑슨모빌사의, 하이트렐은 듀폰사의 등록상표임.

## 펌프의 사이즈

- 최대높이 : 762 mm
- 최대넓이 : 600 mm
- 최대깊이 : 204 mm

## 펌프의 무게

- 폴리프로피렌 : 29.9 Kg
- PVDF : 43.1 Kg

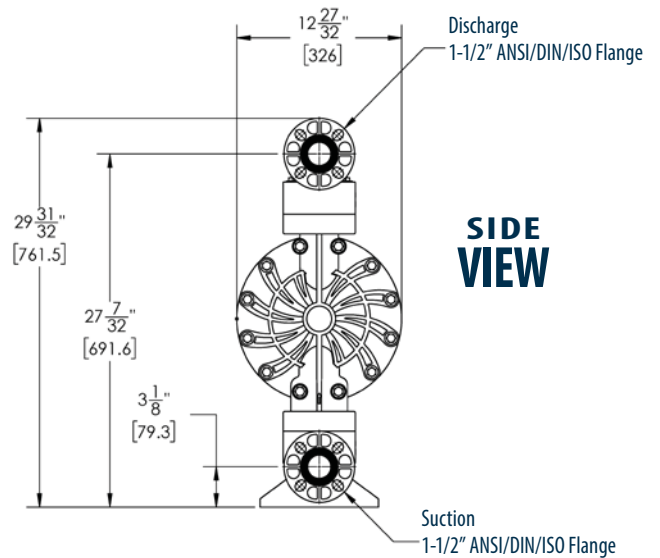
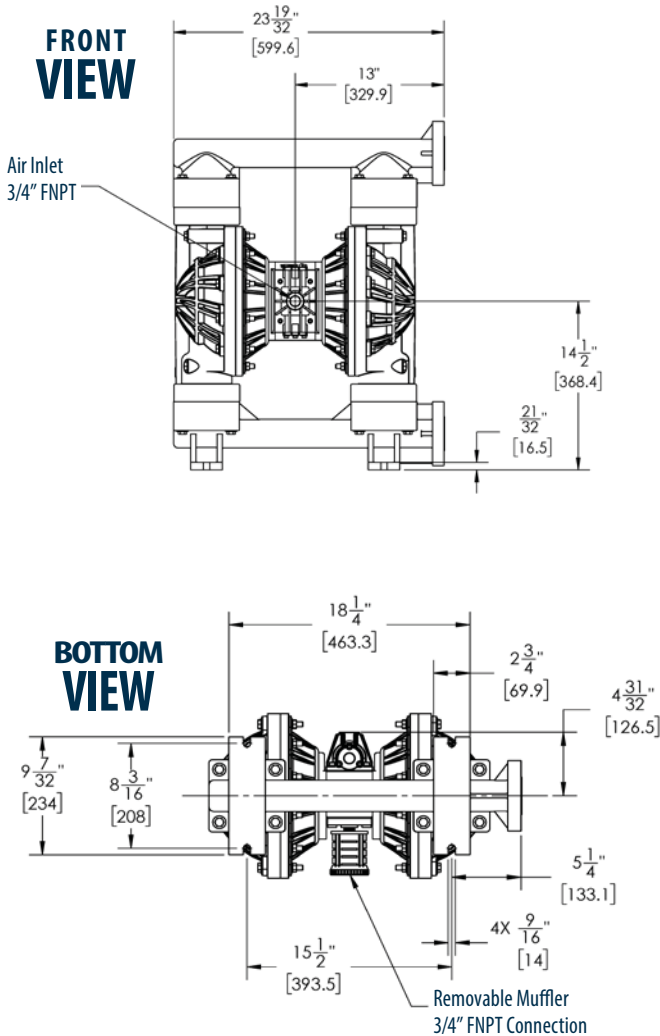

**FTI AIR**

921 GREENGARDEN ROAD ERIE, PA 16501  
 Tel: (800) 934-9384 • Fax: (814) 459-3460  
[www.FTIAIR.com](http://www.FTIAIR.com)

