



# Model FT15S 메탈

## AIR OPERATED DOUBLE DIAPHRAGM PUMPS

### 펌프 사양

- 흡입/토출 구경 : 1.5" x 1.5"
- 포트 위치 : 중앙
- 배관연결 타입 : FNPT, BSPT
- 에어 흡입&배기 사이즈 : 3/4 FNPT x 3/4" FNPT
- \* 요청에 따라 ANSI/DIN/ISO Flange 연결타입도 가능.

### 펌프 능력/용량

- 최대유량 : 500 lpm
- 최대 공기공급 압 : 8.3 Bar
- 한타당 용적 : 1.2 Liter
- 최소 공기흡입 압 : 0.7Bar
- 입자 최대 사이즈 : 8.9 mm
- 소음레벨 : 77 dB(A)
- 가동온도 : 탄성체에 의해 결정.



### FT15 Performance

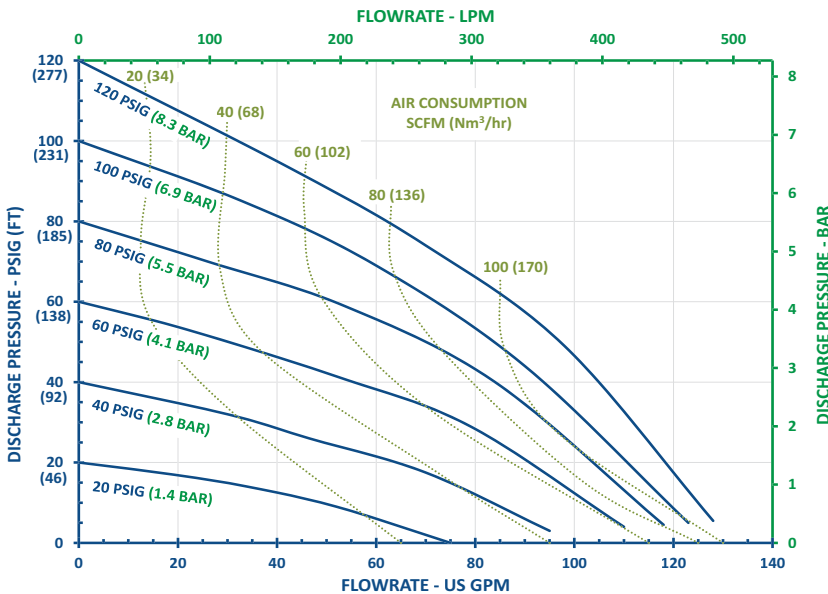

Note: Full stroke diaphragm allows performance to be equal for all elastomers.

### Typical Applications

- Acids & Bases
- Plating Solutions
- Wastewater
- Paints, Inks, Solvents
- Ceramic Slip and Glaze
- Lubricants and Oils

### Typical Industries

- Mining
- Paints and Coatings
- Ceramics
- Pulp and Paper
- Electroplating & Anodizing
- Wastewater
- Marine
- Chemical Manufacturing & Distribution
- OEM's

## 펌프의 구조

- 접촉면 재질 : SS316
- 다이어그램 재질 : 네오프렌, 산토프렌, FKM, EPDM, PTFE, Buna, Hytrel, Polyurethane
- 에어 밸브 : GFRP, 알루미늄
- 볼 재질 : 네오프렌, Buna, EPDM, FKM, 산토프렌, PTFE
- 시트 재질 : 알루미늄, SS316, PTFE, Hytrel, Buna, 네오프렌, EPDM, FKM, 산토프렌, 폴리우레탄
- 오링 재질 : 네오프렌, Buna, EPDM, FKM, PTFE, FEP/FKM

\* 산토프렌은 엑손모빌사의, 하이트렐은 듀폰사의 등록 상표임.

## 펌프의 사이즈

- 최대높이 : 746 mm
- 최대넓이 : 520 mm
- 최대깊이 : 326 mm

## 펌프의 무게

- SS316 : 57.6 Kg

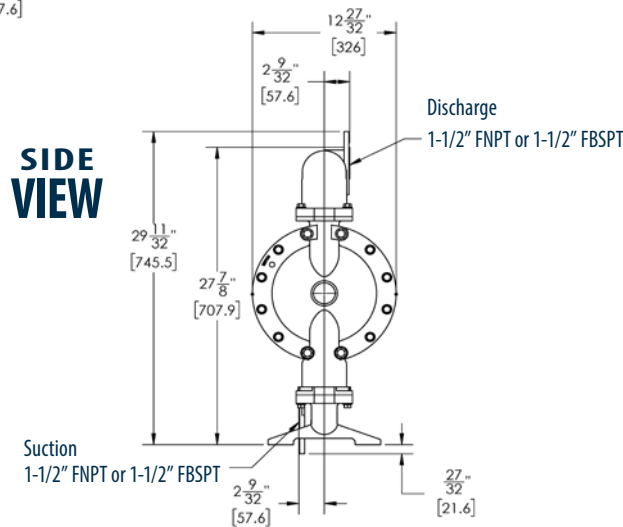
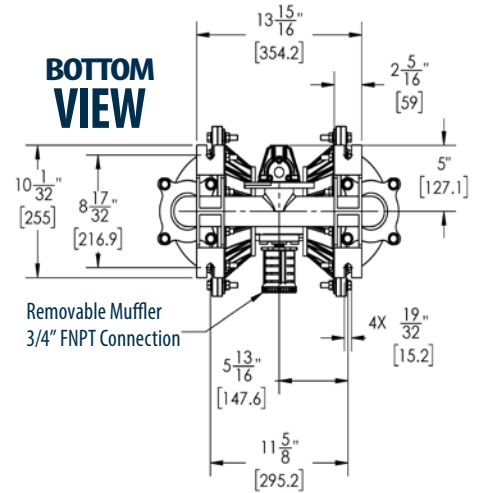
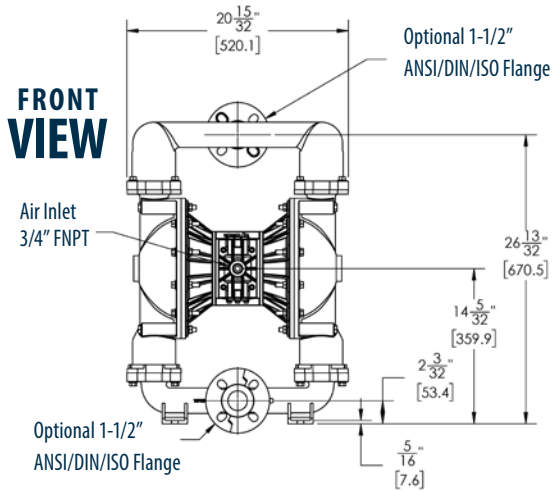

**FTI AIR**

921 GREENGARDEN ROAD ERIE, PA 16501  
Tel: (800) 934-9384 • Fax: (814) 459-3460  
www.FTIAIR.com

